



2016

OFF-ROAD CATALOG



ABOUT	4-5
WHELEN HISTORY	6-7
MANUFACTURING PROCESS	8-9
JOEY LOGANO & NASCAR®	10-11
INTRO	12-13
FEATURES	14-15
SINGLE ROW CONTINUUM™	16-19
DUAL ROW CONTINUUM	20-23
CONTINUUM 3 & 6	24-25
COMPARE CONTINUUM MODELS	26-27
CONTINUUM MODELS & ACCESSORIES	28-29
WARNING LIGHTS	30-35
ILLUMINATION LIGHTS	35-37
BRAKE/TAIL/TURN & MISCELLANEOUS	38-39

About

Whelen Engineering designs and manufactures high performance Super-LED® spot and flood lighting, providing you with the greatest visibility possible.

Constructed with the same solid-state electronics and hard-coated lenses as our high quality Emergency Warning lights, Whelen's off-road products are engineered for maximum intensity and long LED life.



History of Whelen Engineering Company, Inc.

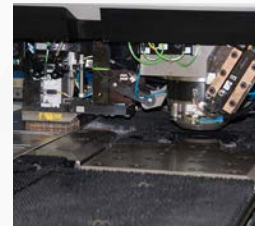

1952
George W. Whelen invents the first rotating aircraft "anti-collision" beacon in his garage in Deep River, Connecticut.

1984
Whelen moves from Deep River, Connecticut to its current Corporate Headquarters in Chester, Connecticut.

1987
A second manufacturing plant is added in Charlestown, New Hampshire.

1991
The New Hampshire plant expands to house plastic injection molding equipment.

The tool and die machine shop begins as a servicing shop for parts before they are run in molding. Today, 90% of all molding tools are made in-house from raw steel.

2005
Whelen becomes the entitlement sponsor of the NASCAR® Whelen Modified Tour and the NASCAR Whelen Southern Modified Tour. Whelen also begins sponsorship as the Official Warning Lights of NASCAR.

2007
Sheet metal fabrication is implemented.

Whelen becomes the entitlement sponsor of the NASCAR Whelen All American Series.

2011
Hard coating technology develops.

2013
The production machine shop opens, housing 26 machines, 5 axis mills, lathes with live tooling, and screw machines. Parts made from raw housing or machined casting go into many finished products.

2013
Whelen becomes the entitlement sponsor of the NASCAR Whelen Euro Series.

1963
Whelen becomes the first in the industry to utilize strobe light technology.

1975
Whelen releases its first fully enclosed lightbar.

1988
Transformer winding is introduced, using automated winding machines in order to increase part supply.

2000
Whelen introduces the first all LED lightbar.

2003
Whelen implements surface mount technology.

2004
Whelen develops an LED floodlight.

2008
Powder coating technology is implemented.

2012
Vacuum metalizing technology is developed.

2014
Whelen opens the only environmentally friendly printed circuit board manufacturing facility in North America with zero hazardous emissions.

Whelen enters the Off-Road market with the Continuum™ series.

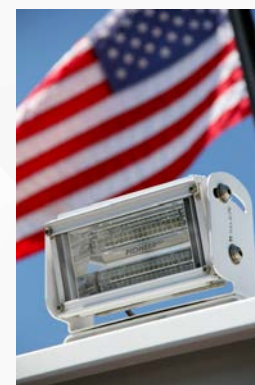



PRODUCTION

All Whelen products are designed, manufactured, and assembled in our Connecticut and New Hampshire facilities.



Hard coating technology utilizes an automated line where UV, abrasion, and chemical resistant coating is applied to all plastic lensing.



Vacuum metalizing technology coats all reflectors with a thin layer of pure vaporized aluminum within a sealed chamber. Bringing this process in-house yields a 10% increase in light output due to improved surface quality and purity.



Printed circuit boards are manufactured in-house. Whelen's PCB shop is the the only environmentally friendly printed circuit board manufacturing facility in North America with zero hazardous emissions.



Surface mount technology deposits electronic components onto PCB using robotic nozzles. All testing and programming of PCB is done in a continuous automated line.



Sheet metal fabrication utilizes lasers to create brackets and a wide variety of metal components used in almost every Whelen product. A five axis laser is used to cut complex metal parts that do not come in a flat sheet.



Powder coating technology uses an automated line which washes, dries, applies powder, and oven bakes.

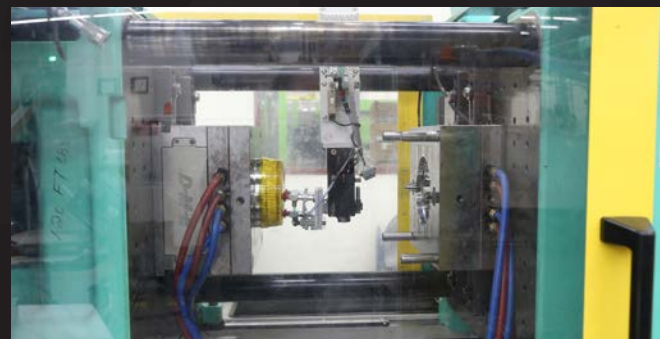

Plastic injection molding equipment manufactures all plastic parts, from optical grade polycarbonate to thermally conductive composites.



Silicone molding is a liquid injected molding process. Silicone allows for use of parts that need to be flexible and water resistant. This material is often utilized to make a watertight seal in an assembly.



Continuum™ **Sub-Assembly**



Continuum **Final Assembly**



NASCAR®

For over 25 years Whelen has supported NASCAR® and its grass roots racing series. In 2014, we welcomed NASCAR Sprint Cup Series driver Joey Logano to our family of motorsport partnerships.

We are also proud to provide the Official Warning Lights and the Official Vehicle Illumination Lights of NASCAR. Since 1952, all Whelen products have been and continue to be designed, manufactured, and assembled in the U.S.A.



Joey Logano

*NASCAR Sprint Cup Series Driver
2015 DAYTONA 500 Champion*

CONTINUUM™

Designed to deliver maximum light intensity and long LED life, Continuum brings Whelen's advanced Super-LED® technology to off-road applications.

Solid-state electronics and hard-coated lenses withstand harsh environments while interchangeable modules and advanced optics give your vehicle the reliable performance and durability Whelen is known for.



FEATURES

- Spot or Flood optic LED modules
- Clear or Smoked lenses
- IP67 rated for dust and water resistance
- Universal "L" bracket mount standard, other mounting options available
- Easily serviceable front-load design
- Black powder coated extruded aluminum housing protects the lightbar from environmental damage
- Plug & Play waterproof wiring harness with waterproof relay and switch included
- Five year warranty



Continuum™ Single Row



Length	Height	Depth	Weight	VDC	LED*	Raw Lumens*	Amps*
11.55" (293mm), 21.80" (554mm), 32.05" (814mm), 42.30" (1074mm), 52.55" (1335mm)	2.00" (51mm)	3.00" (76mm)	2.45lbs, 4.25lbs, 6.25lbs, 8.15lbs, 10.00lbs	12	9	2100	2.3

*Per Module



2.00"
(51mm)

**Actual Height

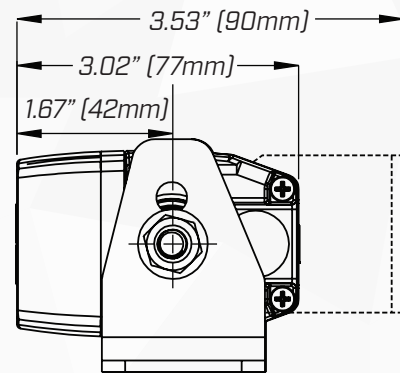

**Actual Inches (Actual Millimeters)





10"



20"



30"



40"



50"



11.55" (293mm)

21.80" (554mm)

32.05" (814mm)

42.30" (1074mm)

52.55" (1335mm)

Continuum™ Dual Row



Length	Height	Depth	Weight	VDC	LED*	Raw Lumens*	Amps*
11.55" (294mm), 21.80" (554mm), 32.05" (814mm), 42.30" (1074mm), 52.55" (1335mm)	3.40" (86mm)	3.04" (77mm)	3.70lbs, 6.60lbs, 9.50lbs, 12.45lbs, 15.25lbs	12	18	5000	5.0

*Per Module

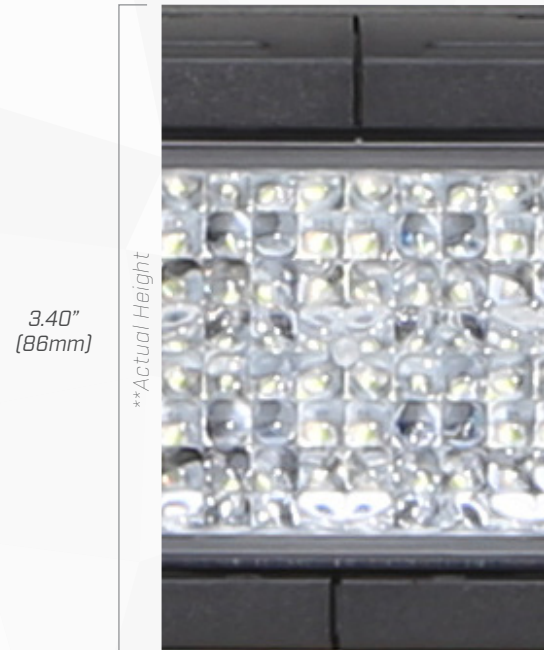

3.40" (86mm)

**Actual Height

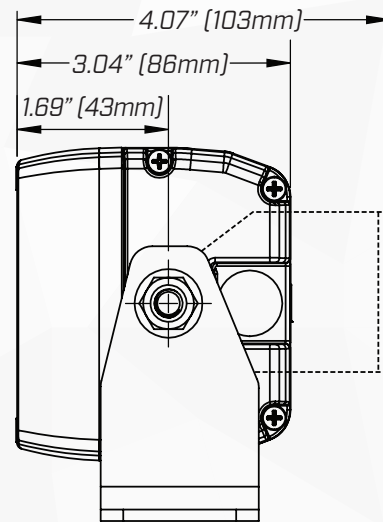

**Actual Inches (Actual Millimeters)





Continuum™ 3 & 6

Continuum 3



4.20" (107mm)

1.80"
(46mm)

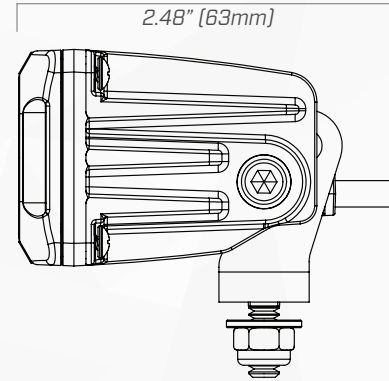

2.48" (63mm)

Length	Height	Depth	Weight	VDC	LED	Raw Lumens	Amps
4.20" (107mm)	1.80" (46mm)	2.48" (63mm)	1.00 lb	12	3	950	1.0

Continuum 6



4.20" (107mm)

2.80"
(71mm)

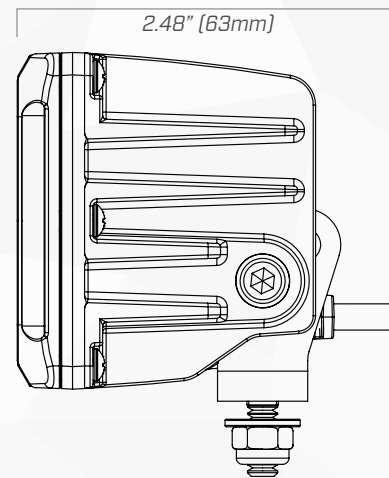

2.48" (63mm)

Length	Height	Depth	Weight	VDC	LED	Raw Lumens	Amps
4.20" (107mm)	2.80" (71mm)	2.48" (63mm)	1.24 lbs	12	6	1900	2.0

Actual Inches (Actual Millimeters)





Product	Single Row	Dual Row	3	6
Length	11.55" (293mm) 21.80" (554mm) 32.05" (814mm) 42.30" (1074mm) 52.55" (1335mm)	11.55" (294mm) 21.80" (554mm) 32.05" (814mm) 42.30" (1074mm) 52.55" (1335mm)	4.20" (107mm)	4.20" (107mm)
Height	2.00" (51mm)	3.40" (86mm)	1.80" (46mm)	2.80" (71mm)
Depth	3.00" (76mm)	3.04" (77mm)	2.48" (63mm)	2.48" (63mm)
Weight	2.45lbs 4.25lbs 6.25lbs 8.15lbs 10.00lbs	3.70lbs 6.60lbs 9.50lbs 12.45lbs 15.25lbs	1.00 lb	1.24 lbs
VDC	12	12	12	12
LED*	9	18	3	6
Raw Lumens*	2100	5000	950	1900
Amps*	2.3	5.0	1.0	2.0

*Per Module



SPOT



FLOOD



SMOKED



SRAS



RC6K



BKT87784

Continuum 10"	Single	Dual
Spot	S1S	C1S
Flood	S1F	C1F
Spot, Smoked Lens	S1SX	C1SX
Flood, Smoked Lens	S1FX	C1FX

Continuum 20"	Single	Dual
Spot/Spot	S2SS	C2SS
Flood/Flood	S2FF	C2FF
Spot/Flood	S2SF	C2SF
Flood/Spot	S2FS	C2FS
Spot/Spot, Smoked Lenses	S2SSX	C2SSX
Flood/Flood, Smoked Lenses	S2FFX	C2FFX
Spot/Flood, Smoked Lenses	S2SFX	C2SFX
Flood/Spot, Smoked Lenses	S2FSX	C2FSX

Continuum 30"	Single	Dual
Spot/Spot/Spot	S3SSS	C3SSS
Flood/Flood/Flood	S3FFF	C3FFF
Spot/Flood/Spot	S3SFS	C3SFS
Flood/Spot/Flood	S3FSF	C3FSF
Spot/Spot/Spot, Smoked Lenses	S3SSSX	C3SSSX
Flood/Flood/Flood, Smoked Lenses	S3FFFX	C3FFFX
Spot/Flood/Spot, Smoked Lenses	S3SFSX	C3SFSX
Flood/Spot/Flood, Smoked Lenses	S3FSFX	C3FSFX

Continuum 3 & 6	3	6
Black Finish	RC3K	RC6K

Continuum 40"	Single	Dual
Spot/Spot/Spot/Spot	S4SSSS	C4SSSS
Flood/Flood/Flood/Flood	S4FFFF	C4FFFF
Spot/Flood/Flood/Spot	S4SFFS	C4SFFS
Flood/Spot/Spot/Flood	S4FSSF	C4FSSF
Spot/Spot/Spot/Spot, Smoked Lenses	S4SSSX	C4SSSX
Flood/Flood/Flood/Flood, Smoked Lenses	S4FFFX	C4FFFX
Spot/Flood/Flood/Spot, Smoked Lenses	S4SFSX	C4SFSX
Flood/Spot/Spot/Flood, Smoked Lenses	S4FSFX	C4FSFX

Continuum 50"	Single	Dual
Spot/Spot/Spot/Spot/Spot	S5SSSSS	C5SSSSS
Flood/Flood/Flood/Flood/Flood	S5FFFFF	C5FFFFF
Spot/Spot/Flood/Spot/Spot	S5SFFSS	C5SFFSS
Spot/Flood/Flood/Flood/Spot	S5SFFFS	C5SFFFS
Spot/Flood/Spot/Flood/Spot	S5SFSFS	C5SFSFS
Flood/Flood/Spot/Flood/Flood	S5FFSFF	C5FFSFF
Flood/Spot/Flood/Spot/Flood	S5FSFSF	C5FSFSF
Flood/Spot/Spot/Spot/Flood	S5FSSSF	C5FSSSF
Spot/Spot/Spot/Spot/Spot, Smoked Lenses	S5SSSSSX	C5SSSSSX
Flood/Flood/Flood/Flood/Flood, Smoked Lenses	S5FFFFFX	C5FFFFFX
Spot/Spot/Flood/Spot/Spot, Smoked Lenses	S5SFFSSX	C5SFFSSX
Spot/Flood/Flood/Flood/Spot, Smoked Lenses	S5SFFFSX	C5SFFFSX
Spot/Flood/Spot/Flood/Spot, Smoked Lenses	S5SFSFSX	C5SFSFSX
Flood/Flood/Spot/Flood/Flood, Smoked Lenses	S5FFSFFX	C5FFSFFX
Flood/Spot/Flood/Spot/Flood, Smoked Lenses	S5FSFSFX	C5FSFSFX
Flood/Spot/Spot/Spot/Flood, Smoked Lenses	S5FSSSFX	C5FSSSFX

Generic Mounts	
BKT47097	Universal L Bracket Mtg. Kit - Dual Row
BKT47379	Pipe Mount - 3-1/4"
BKT47378	Pipe Mount - 3"
BKT47377	Pipe Mount - 2-7/8"
BKT47376	Pipe Mount - 2-3/4"
BKT47375	Pipe Mount - 2-5/8"
BKT47374	Pipe Mount - 2-1/2"
BKT47373	Pipe Mount - 2-3/8"
BKT47372	Pipe Mount - 2-1/4"
BKT47371	Pipe Mount - 2"
BKT47370	Pipe Mount - 1-7/8"
BKT47316	Pipe Mount - 1-3/4"
BKT47369	Pipe Mount - 1-45/64"
BKT47368	Pipe Mount - 1-5/8"
BKT47318	Pipe Mount - 1-1/2"
BKT47367	Pipe Mount - 1-1/4"
BKT47366	Pipe Mount - 1-1/8"
BKT47365	Pipe Mount - 1"
BKT47364	Pipe Mount - 7/8"

Vehicle Specific Mounts	
BKT47468	Dodge Ram, 2012-2015 Lower Grill Mount, 20" DR & SR Continuum
BKT66466	Ford F-150, 2015 Lower Grill Mount, 10" DR & SR Continuum
BKT6F789	Ford Super Duty, 2009-2014 Lower Grill Mount, 20" DR & SR Continuum
BKT47585	Toyota Tacoma, 2015 Lower Grill Mount, 30" DR & SR Continuum
BKT47521	Ford Super Duty, 2015 Bumper Mount, 40" DR & (2X) SR Continuum
BKT47264	Jeep JK Hood Mount 10" DR & SR Continuum
BKT47265	Jeep JK Hood Mount 20" DR & SR Continuum
BKT87784	Jeep JK Brow Mount 50" DR & SR Continuum
BKT87785	Jeep TJ Brow Mount 50" DR & SR Continuum

Flush Mount Retainer	3	6
Black Finish	RC3K	RC6K

Parts & Accessories	Single	Dual
Wiring Kit - 10"	WKSR10	WKDR10
Wiring Kit - 20"	WKSR20	WKDR20
Wiring Kit - 30"	WKSR30	WKDR30
Wiring Kit - 40"	WKSR40	WKDR40
Wiring Kit - 50"	WKSR50	WKDR50
LED 10" Module, Spot, Clear Lens	SRS	DRS
LED 10" Module, Spot, Smoked Lens	SRSX	DRSX
LED 10" Module, Flood, Clear Lens	SRF	DRF
LED 10" Module, Flood, Smoked Lens	SRFX	DRFX
LED 10" Amber Module, Spot, Clear Lens	SRAS	DRAS
LED 10" Amber Module, Spot, Smoked Lens	SRASX	DRASX
LED 10" Amber Module, Flood, Clear Lens	SRAF	DRAF
LED 10" Amber Module, Flood, Smoked Lens	SRAF	DRAF

Covers	Single	Dual
Cover - Amber	LCSRA	LCORA
Cover - Clear	LCSRC	LCORC
Cover - Red	LCSRR	LCORR
Cover - Black	LCSRK	LCORK
Cover - White	LCSRW	LCORW

Covers	3	6
Cover - Amber	LCC3A	LCC6A
Cover - Clear	LCC3C	LCC6C
Cover - Red	LCC3R	LCC6R
Cover - Black	LCC3K	LCC6K
Cover - White	LCC3W	LCC6W



Warning

OS Series

- Fully encapsulated for moisture, vibration, and corrosion resistance
- Hard-coated lenses resist environmental damage from sand, sun, salt, and road chemicals
- Surface mount, includes Chrome flange
- 1" (25mm) H x 1-1/2" (48mm) W x 1/2" (13mm) D



<i>OSR00MCR</i>	Red Marker/Clearance Light
<i>OSA00MCR</i>	Amber Marker/Clearance Light

Vertex™ Series

- Self-contained light with in-line lamp driver
- Designed to mount in composite style headlight or taillight, or surface mount to exterior surfaces with flange mount option
- Fully encapsulated for moisture, vibration, and corrosion resistance
- Hard-coated lenses resist environmental damage from sand, sun, salt, and road chemicals
- Synchronize to other Whelen sync products
- 1" (26mm) H x 1-5/8" (41mm) Dia.



<i>VTX609A</i>	Amber
<i>VTX609C</i>	White
<i>VTXFB</i>	Black Flange
<i>VTXFC</i>	Chrome Flange

ION™ Series

- Surface mount Super-LED® lighthouse
- Hard-coated lenses resist environmental damage from sand, sun, salt, and road chemicals
- Synchronize to other Whelen sync products
- 1-11/16" (43mm) H x 1-1/8" (28mm) D x 5-15/16" (150mm) L



<i>IONSMA</i>	Amber
<i>IONSMC</i>	White

LINV2™ V-Series™

- Combination 180° warning and puddle light
- Includes Black flange
- Fully encapsulated for moisture, vibration, and corrosion resistance
- Hard-coated lenses resist environmental damage from sand, sun, salt, and road chemicals
- Synchronize to other Whelen sync products
- 1-1/2" (40mm) H x 1-5/8" (42mm) D x 3-7/8" (98mm) L



<i>LINV2A</i>	Amber
<i>LINV2C</i>	White

*Five Year Warranty

Warning

V23™ Series

- 2-in-1 warning and illumination light
- Available with a patented Linear-LED® designed reflector assembly
- Surface mount, includes Black or Chrome flange
- Hard-coated lenses resist environmental damage from sand, sun, salt, and road chemicals
- 2-11/16" (68mm) H x 1-1/2" (38mm) D x 4-1/4" (109mm) L



V23ATPB Amber, Black Flange
V23ATPC Amber, Chrome Flange

M2 Series

- Available with a patented Linear-LED designed reflector assembly
- Surface mount
- Hard-coated lenses resist environmental damage from sand, sun, salt, and road chemicals
- Synchronize to other Whelen sync products
- 2-1/2" (64mm) H x 4" (102mm) W x 1" (25mm) D



M2A Amber
M2C White
M2FC Chrome Flange
M2FB Black Flange
M2GRDM Grommet Mount Kit

M6 Series

- Available with a patented Linear-LED designed reflector assembly
- Surface mount
- Hard-coated lenses resist environmental damage from sand, sun, salt, and road chemicals
- 4-5/16" (109mm) H x 6-3/4" (170mm) W x 1-3/8" (35mm) D



M6A Amber
M6C White
M6ZC Scenelight
M6FC Chrome Flange
M6FB Black Flange
M6BRUSH Black Brush Guard

*Five Year Warranty





Warning

2G & 5G Series

- Fully encapsulated for moisture, vibration and corrosion resistance
- Hard-coated lenses minimize environmental damage from the sun, salt, and road chemicals
- Grommet mount (includes vinyl grommet)
- 2G - 5-1/2" (140mm) Dia. x 1-1/4" (32mm) D (with grommet)
- 5G - 3-3/16" (81mm) H x 7-7/16" (189mm) W x 1-1/4" (32mm) D (with grommet)



2GA00FAR	Amber 2G
5GA00FAR	Amber 5G
5GCD0WCR	White 5G Back-up Light

500 Series

- Available with Linear or TIR Super-LED® optics
- Hard-coated lenses minimize environmental damage from the sun, salt, and road chemicals
- 1-5/8" (41mm) H x 1-3/4" (44mm) D x 5" (127mm) L



50A02ZAR	Amber 500 LIN6
5LSMAB	Black LIN6 Surface Mount Adapter
5LSMAC	Chrome LIN6 Surface Mount Adapter
50A03ZAR	Amber 500 TIR6
5TSMAB	Black TIR6 Surface Mount Adapter
5TSMAC	Chrome TIR6 Surface Mount Adapter
5GROMMET	Grommet Mount Kit

Illumination

3" Round Series

- Hard-coated lenses minimize environmental damage from sand, sun, salt, and road chemicals
- Fully encapsulated for moisture, vibration, and corrosion resistance
- 3" (76mm) Dia. x 7/16" (12mm) Depth



3SC0CDR	White Compartment Light
3SA0DFAR	Amber
3SBCCDR	Blue/White Compartment Light
3SRCCDR	Red/White Compartment Light
3SR0CDRR	Red

OS Series

- Fully encapsulated for moisture, vibration, and corrosion resistance
- Hard-coated lenses resist environmental damage from sand, sun, salt, and road chemicals
- Surface mount, includes Chrome flange
- 1" (25mm) H x 1-1/2" (48mm) W x 1/2" (13mm) D



OSCOEDCR	White Illumination Light
----------	--------------------------

*Five Year Warranty

Illumination

6" Round Series

- Interior compartment light
- 18-LED model features High/Low intensity operating mode
- Low profile surface mount
- 6" (152mm) Dia. x 5/8" (16mm) D



60COEJCS	6 LED
60COEHCR	18 LED

Perimeter Enhancement Light

- 40° downward projected light for illumination of vehicle's perimeter
- Surface mount, includes Chrome or Black housing
- 1" (25mm) H x 1-3/8" (35mm) D x 11-1/2" 292mm) L



PELCB	White, Black Flange
PELCC	White, Chrome Flange

Strip-Lite™ Series

- Slim rectangular shape offers mounting versatility in tight spaces
- Fully encapsulated for moisture, vibration, and corrosion resistance
- Hard-coated lenses minimize environmental damage from the sun, salt and road chemicals
- Surface mount



PSCDADCR	6 LED
PSCCDCR	18 LED

Fluorent Plus™ Series

- 120° Super-LED® light assemblies
- Includes both a C clip for snap-in and P clip for fixed mounting
- Silicone rubber end caps
- 5/8" (16mm) H



F09PC	9" Lens
F18PC	18" Lens



*Five Year Warranty



Brake/Tail/Turn

400 Series

- Super-LED® brake/tail/turn light
- Surface mount
- Fully encapsulated for moisture, vibration, and corrosion resistance
- Hard-coated lenses minimize environmental damage from the sun, salt, and road chemicals
- Five year warranty
- 3-3/16" (77mm) H x 2-3/4" (69mm) D x 4-15/16" (124mm) L



40BTT Red Brake/Tail/Turn

600 Series

- Brake/tail/turn or arrow turn light
- Hard-coated lenses minimize environmental damage from the sun, salt, and road chemicals
- Five year warranty
- 4-1/8" (105mm) H x 1-3/8" (35mm) D x 6-1/2" (165mm) L

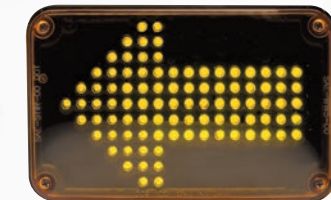

60A00TAR Amber Turn Signal
 60BTT Red Brake/Tail/Turn
 6FLANGEB Black Flange
 6EFLANGE Chrome Flange

Miscellaneous

Power Control Centers & Switches

- Eight position keypad with remote relay module
- Three 20 amp and five 10 lamp relays
- Adjustable bail bracket mounting
- Two year warranty
- 7 1/4" (184mm) L x 4 3/4" (121mm) W x 1 1/4" (32mm) H



PCCBR 8 Switch Control

WSSC Series

- Combination siren and speaker in a single, compact unit
- Heavy-duty 30 watt amplified siren
- 10 siren tones and Air Horn with override
- Aluminum housing and water-resistant connectors for vibration and moisture resistance
- Two year warranty
- 5.44" (138mm) L x 4 5/8" (118mm) W x 4.31" (110mm) H



WSSC30 30W Siren and Speaker
 WSSPA30 30W Siren and Speaker with Public Address



51 Winthrop Road, Chester, CT 06412-0684
860-526-9504
www.whelen.com



Whelen Engineering reserves the right to upgrade and improve products without notice.

NASCAR® is the registered trademark of the National Association for Stock Car Auto Racing, Inc.
© 2015 Whelen Engineering Company, Inc.
Printed in the U.S.A. Form No. 13031A - 12/15

ISO 9001:2008 Registered QMS

WhelenMTRS

WhelenENG

