

2020

Police Interceptor Utility

Police Interceptor Utility Hybrid

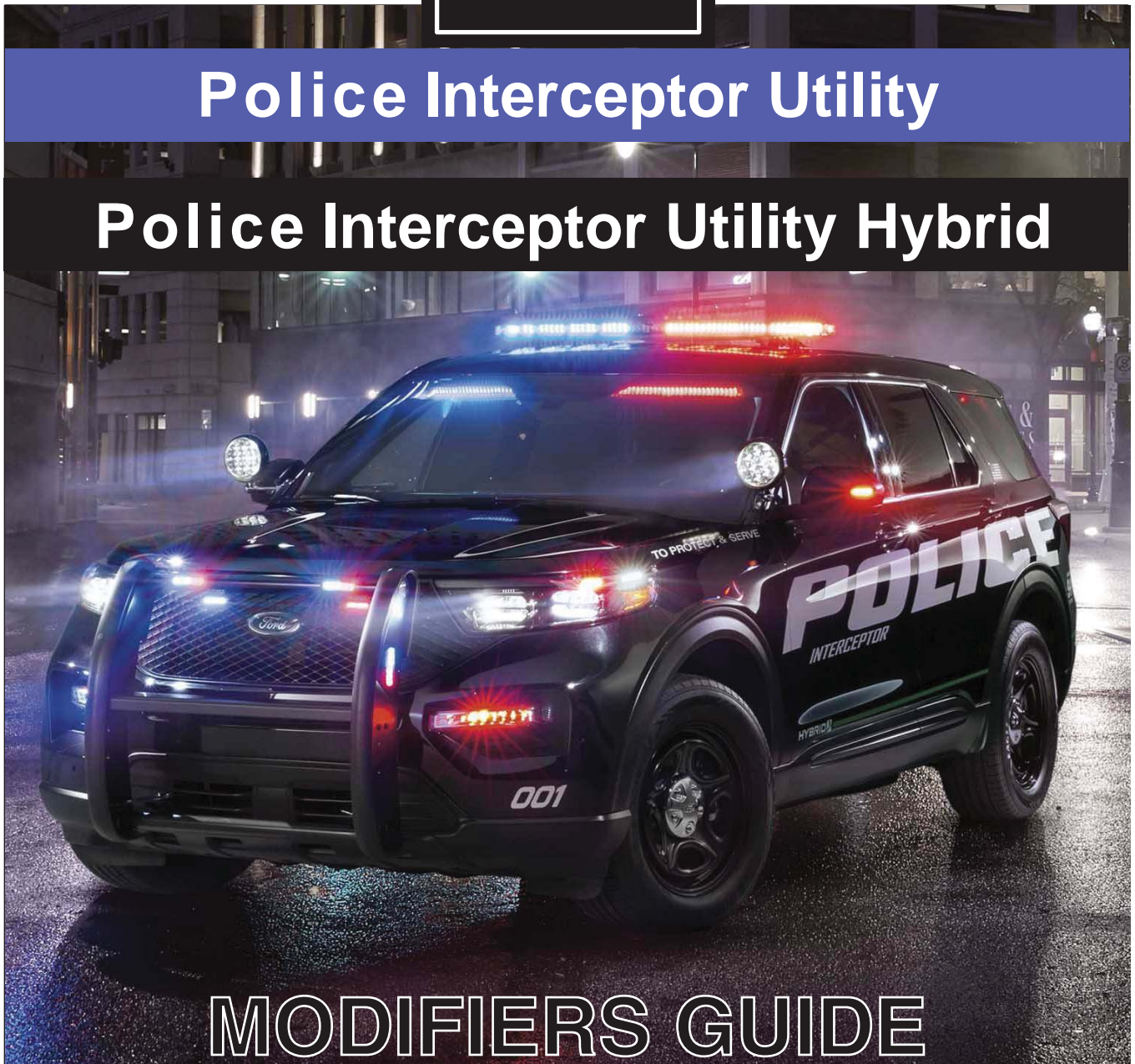

MODIFIERS GUIDE

## SECTION 0: Introduction

---

### Table of Contents

Contents	PAGE
Introduction .....	0-2
Genuine Ford Accessories For Your Vehicle .....	0-2

# Introduction

## Introduction

Ford Motor Company has assembled this guide to assist vehicle modifiers in producing a safe and quality vehicle. Ford believes safety and quality come first. To achieve customer satisfaction, we want to assist modifiers in achieving the highest standards of safety and quality in their vehicles.

This book is divided into topics pertinent to vehicle modifiers. References are made to the Workshop Manual for appropriate service procedures, torque specifications, component separation clearances and other standard information which is common with an unmodified vehicle. Specifications unique to this guide are designated.

This modifier guide is not a "how-to" book; it should be used as a checklist to help make sure that certain important steps in the modification process are considered. It is ultimately the responsibility of the upfitter with knowledge of the entire upfit to ensure the checklist is complete. While Ford is providing this information to assist modifiers, it does not warrant the vehicles, methods, materials or the workmanship of the modifier. Ford also does not warrant against failures that result from the modification of a vehicle.

Following the guidelines contained in this guide does not assure individual modifiers that the products they modify comply with US Federal or Canadian Motor Vehicle Safety Standards in effect at the time of the modification. The guidelines set forth are based on engineering analysis of typical vehicles. If the guidelines are followed, the modifier's efforts in certifying vehicles to applicable standards should be aided. Compliance testing that may be required for certification of specific vehicle configurations or construction is the sole responsibility of the individual modifier.

The only model suitable for use in police service is the pursuit-rated Police Interceptor.

DuPont™ and KEVLAR® are trademarks or registered trademarks of DuPont™ or its affiliates.

## Genuine Ford Accessories For Your Vehicle

A wide selection of genuine Ford accessories are available for your vehicle through your local authorized Ford or Ford of Canada dealer. These quality accessories have been specifically engineered to fulfill your automotive needs; they are custom designed to complement the style and aerodynamic appearance of your vehicle. In addition, each accessory is made from high-quality materials that meet or exceed Ford's rigorous engineering and safety specifications. Ford Motor Company will repair or replace any properly installed genuine Ford accessory found to be defective in factory-supplied materials or workmanship during the warranty period, as well as any component damaged by the defective accessory. The accessory will be warranted for whichever provides you the greatest benefit:

- 12 months or 20,000 km (12,000 mi), whichever occurs first; or
- the remainder of your new vehicle limited warranty.

This means that genuine Ford accessories purchased along with your new vehicle and installed by the dealer are covered for the full length of your new vehicle's limited warranty — 3 years or 60,000 km (36,000 mi), whichever occurs first. Contact your dealer for details and a copy of the warranty.

## Considerations When Using or Installing Accessories

For maximum vehicle performance, keep the following information in mind when adding accessories or equipment to your vehicle:

- When adding accessories, equipment, passengers and/or luggage to your vehicle, do not exceed the gross vehicle weight rating (GVWR) or gross axle weight rating (GAWR) as indicated on the Safety Compliance Certification Label. Consult your dealer for specific weight information.
- The Federal Communications Commission (FCC) and Canadian Radio Telecommunications Commission (CRTC) regulates the use of mobile communication systems, such as 2-way radios, telephones and theft alarms that are equipped with radio transmitters. Any such equipment installed in your vehicle should comply with FCC or CRTC regulations and should only be installed by a qualified service technician.
- Mobile communication systems may harm the operation of your vehicle, particularly if they are not properly designed for automotive use.
- To avoid interference with other vehicle functions, such as the anti-lock brake system (ABS), amateur radio users who install radios and antennas onto their vehicle should not locate the antenna in the area of the driver's side hood.
- Electrical or electronic accessories or components that are added to the vehicle by the dealer or the owner may adversely affect battery performance and durability.

## SECTION 2: High Voltage Battery Depowering

---

### Table of Contents

Contents	PAGE
Section 2: High Voltage Battery Depowering .....	2-2
Upper Battery High Voltage Service Disconnect .....	2-2

## Section 2: High Voltage Battery Depowering

### Section 2: High Voltage Battery Depowering

#### Upper Battery High Voltage Service Disconnect

 **WARNING:**

THE HIGH-VOLTAGE SYSTEM MAY RETAIN A DANGEROUS LEVEL OF VOLTAGE FOR A SHORT TIME AFTER THE SERVICE DISCONNECT HAS BEEN REMOVED. WAIT 5 MINUTES FOR THE VOLTAGE TO DISSIPATE BEFORE BEGINNING SERVICE. FAILURE TO FOLLOW THIS INSTRUCTION MAY RESULT IN SERIOUS PERSONAL INJURY OR DEATH.

 **WARNING:**

REMOVING THE BATTERY HIGH VOLTAGE SERVICE DISCONNECT DOES NOT DISSIPATE VOLTAGE INSIDE THE BATTERY PACK. THE BATTERY PACK REMAINS LIVE AND DANGEROUS. CONTACT WITH THE HIGH VOLTAGE BATTERY PACK INTERNALS MAY RESULT IN SERIOUS PERSONAL INJURY OR DEATH.

 **WARNING:**

ELECTRIC VEHICLES DAMAGED BY A CRASH MAY HAVE COMPROMISED HIGH VOLTAGE SAFETY SYSTEMS AND PRESENT A POTENTIAL HIGH VOLTAGE ELECTRICAL SHOCK HAZARD. EXERCISE CAUTION AND WEAR APPROPRIATE PERSONAL PROTECTIVE EQUIPMENT (PPE) INCLUDING HIGH VOLTAGE SAFETY GLOVES AND BOOTS. REMOVE ALL METALLIC JEWELRY, INCLUDING WATCHES AND RINGS. ISOLATE THE HIGH VOLTAGE SYSTEM AS DIRECTED BY THE FORD EMERGENCY RESPONSE GUIDE FOR THE VEHICLE. FAILURE TO FOLLOW THESE INSTRUCTIONS MAY RESULT IN SERIOUS PERSONAL INJURY OR DEATH.

 **WARNING:**

TO PREVENT THE RISK OF HIGH-VOLTAGE SHOCK, ALWAYS FOLLOW PRECISELY ALL WARNINGS AND SERVICE INSTRUCTIONS INCLUDING INSTRUCTIONS TO DEPOWER THE SYSTEM. THE HIGH-VOLTAGE SYSTEM UTILIZES VOLTAGE IN EXCESS OF 300 V DC. THIS VOLTAGE IS PROVIDED THROUGH HIGH-VOLTAGE CABLES TO ITS COMPONENTS AND MODULES. THE HIGH-VOLTAGE CABLES AND WIRING ARE IDENTIFIED BY ORANGE HARNESS TAPE OR ORANGE WIRE COVERING. ALL HIGH-VOLTAGE COMPONENTS ARE MARKED WITH HIGH-VOLTAGE WARNING LABELS WITH A HIGH-VOLTAGE SYMBOL. FAILURE TO FOLLOW THESE INSTRUCTIONS MAY RESULT IN SERIOUS PERSONAL INJURY OR DEATH.

 **WARNING:**

SERVICE OF THE HIGH VOLTAGE SYSTEM ON THIS VEHICLE IS RESTRICTED TO QUALIFIED PERSONNEL. THE REQUIRED QUALIFICATIONS VARY BY REGION. ALWAYS OBSERVE LOCAL LAWS AND LEGISLATIVE DIRECTIVES REGARDING ELECTRIC VEHICLE SERVICE. FAILURE TO FOLLOW THIS INSTRUCTION MAY RESULT IN SERIOUS PERSONAL INJURY OR DEATH.

 **WARNING:**

NEVER CONNECT THE SERVICE DISCONNECT PLUG WHEN A HIGH-VOLTAGE SERVICE COVER IS REMOVED. ALWAYS INSTALL THE COVER PRIOR TO CONNECTING THE SERVICE DISCONNECT PLUG. THE COVER PREVENTS INADVERTENT CONTACT WITH THE HIGH VOLTAGE WHICH IS PRESENT AT SEVERAL POINTS UNDER THE COVER. FAILURE TO FOLLOW THESE INSTRUCTIONS MAY RESULT IN SERIOUS PERSONAL INJURY OR DEATH.

 **WARNING:**

DISCONNECT THE 12V BATTERY BEFORE SERVICING THE DIRECT CURRENT TO ALTERNATING CURRENT (DC-AC) INVERTER OR ALTERNATING CURRENT (AC) POWERPOINT TO PREVENT THE RISK OF HIGH VOLTAGE SHOCK. FAILURE TO FOLLOW THIS INSTRUCTION MAY RESULT IN SERIOUS PERSONAL INJURY.

**NOTICE:**

Do not backprobe, splice or repair the high voltage (orange) wiring. Voltage in the system is approximately 300 volts DC. Damage may occur to equipment added to the system.

**NOTICE:**

None of the Battery Energy Control Module (BECM) wiring should be tapped or spliced to check for battery voltage (power), ground or signals.

## Section 2: High Voltage Battery Depowering

1. Ensure the vehicle transmission gear selector is in the PARK position. Check that the vehicle ready light is off to verify the high voltage system is disconnected. If the vehicle ready light is on, press the Start button to turn off the ignition.
2. Open the hood and locate the high voltage system service disconnect plug.

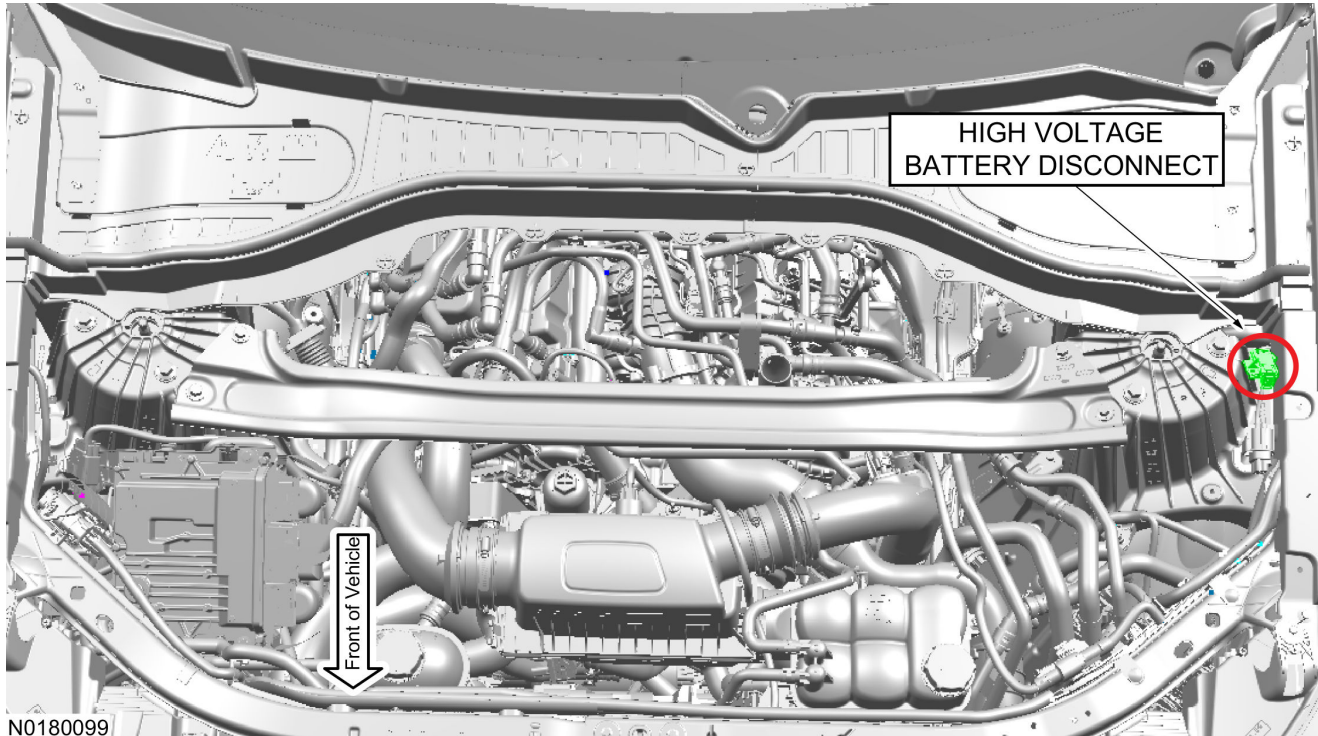

## Section 2: High Voltage Battery Depowering

3. Slide the red lock tab outward (1).
4. Depress the tab and disconnect the high voltage system disconnect (2).
5. **IMPORTANT! A suitable pad lock must be installed to prevent the high voltage plug from accidentally re-engaging (3).**

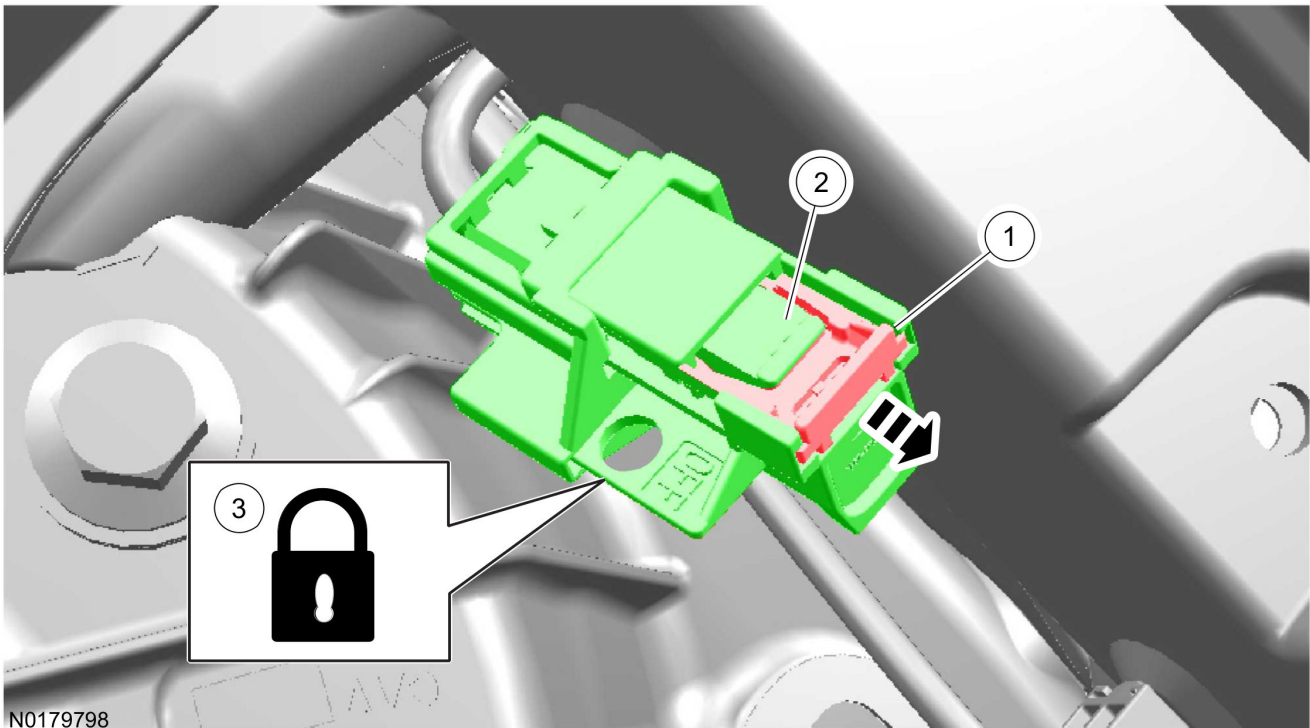

6. Release the clips and remove the 12v battery access cover.

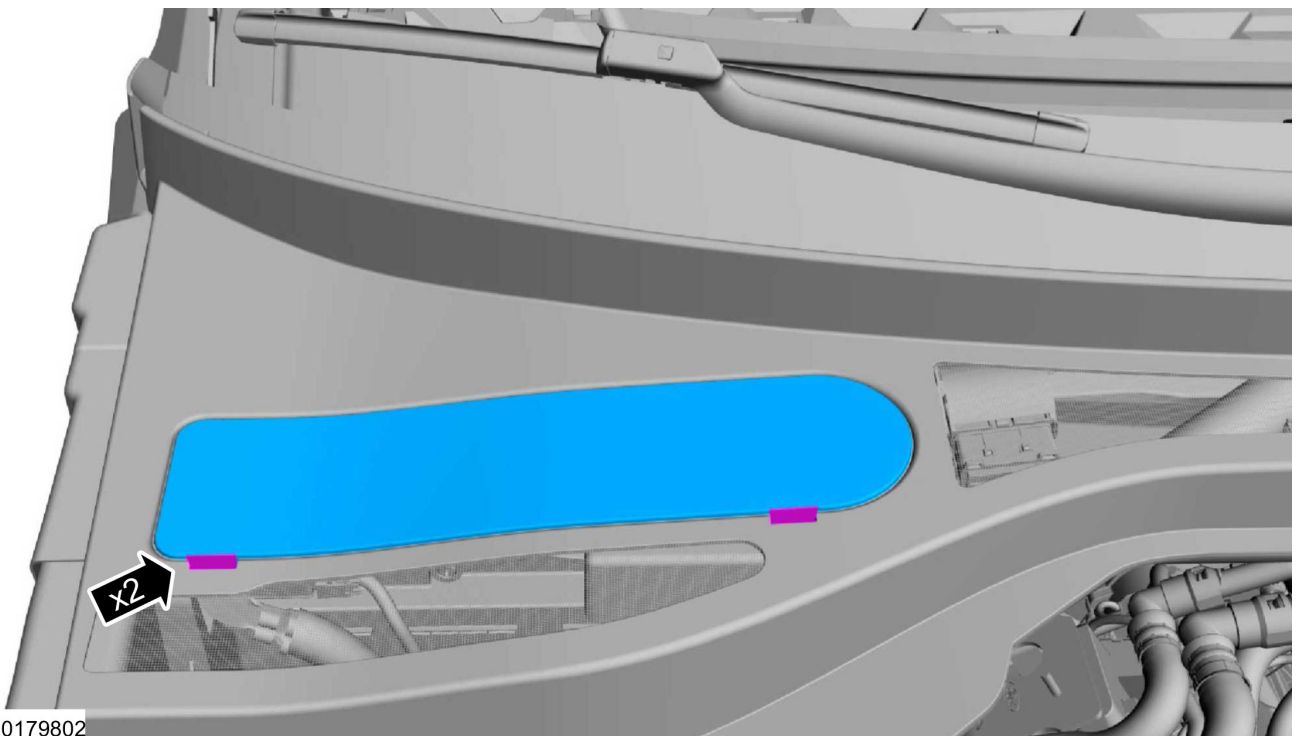

## Section 2: High Voltage Battery Depowering

**NOTICE:**

Make sure the positive 12v battery terminal cover is in position while removing the negative battery cable clamp to prevent damage from a short to the positive terminal.

**NOTICE:**

Be careful not to damage the sensor when removing the terminal from the 12v battery post. Do not pry on the terminals or component damage may occur.

7. Loosen, but do not remove the nut and position the negative battery cable aside.

Be sure to cover the 12v battery cable with electrical tape to prevent the cable from making contact with the battery terminal.

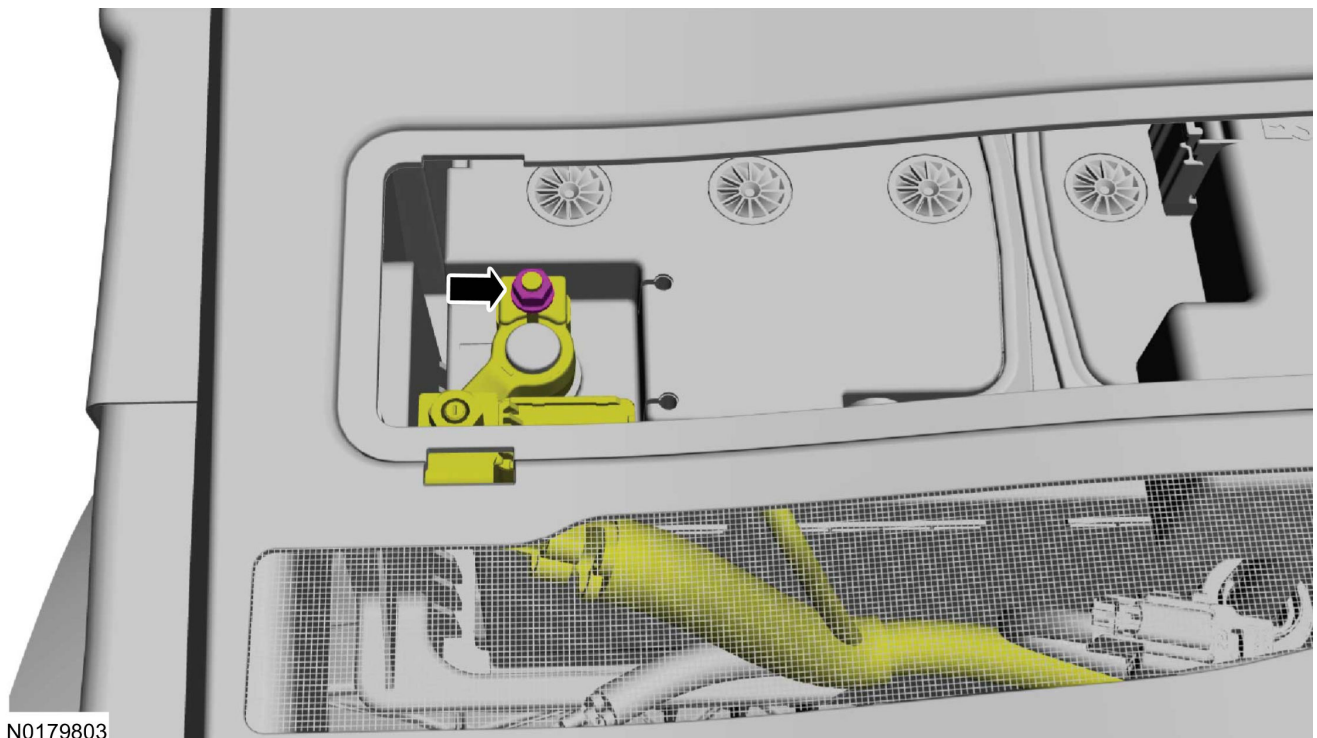



## Section 2: High Voltage Battery Depowering

8. Access the aux 12v battery located in the loadspace compartment.
  - a. Remove the loadspace scuff plate trim panel.



- b. Remove the loadspace floor.



## Section 2: High Voltage Battery Depowering

- c. Remove the push pins and remove the driver side loadspace trim panel.



N0180037

## Section 2: High Voltage Battery Depowering

**NOTICE:**

Make sure the positive battery terminal cover is in position while removing the negative battery cable clamp to prevent damage from a short to the positive terminal.

9. Remove the bolt and position the negative aux 12v battery cable aside.

Be sure to cover the battery cable with electrical tape to prevent the cable from making contact with the battery terminal.

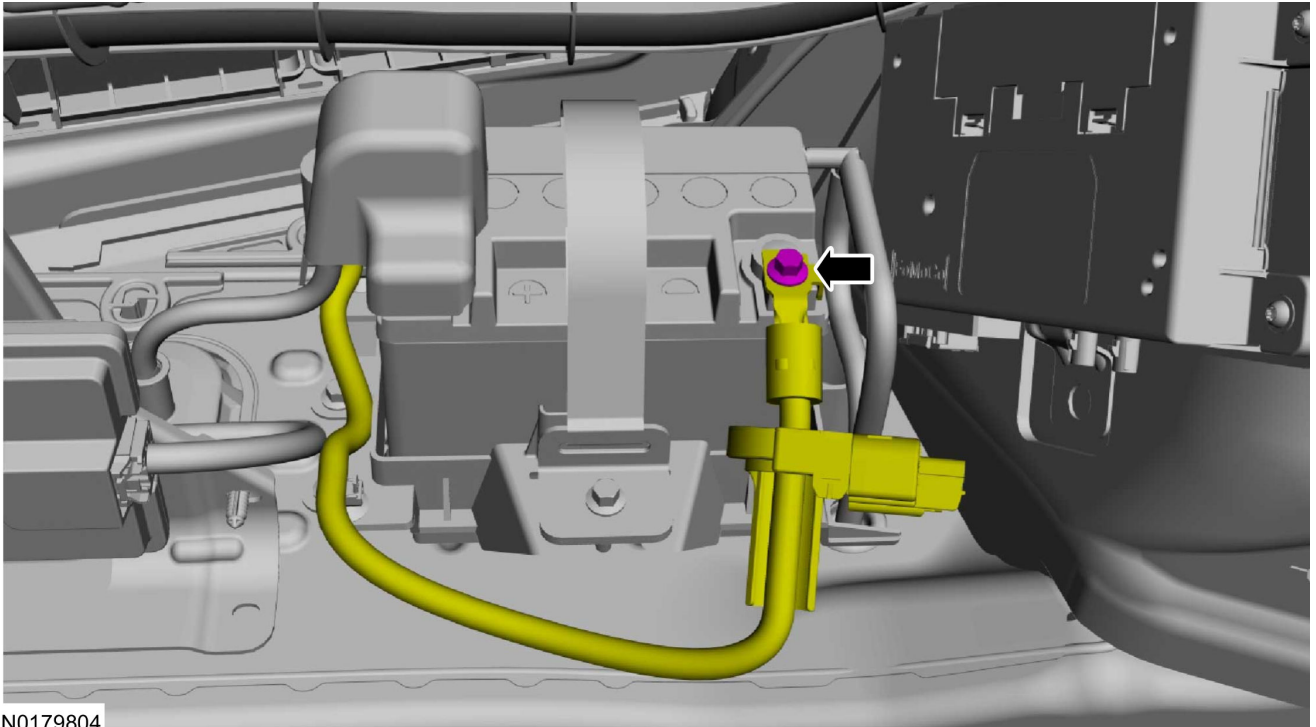

10. Allow the High Voltage system ten (10) minutes to dissipate voltage before servicing any High Voltage component(s).