

CANTROL™ WC

LIGHT AND SIREN SYSTEM FOR TOTAL VEHICLE INTEGRATION AND CONTROL

Create dynamic unified warning by incorporating every light and siren on your cruiser into custom program configurations. Officers keep both hands on the wheel instead of trying to figure out which button to push!

Your warning system becomes your strongest ally for safety because you can pre-configure the proper response to any situation before it happens...before timing is critical ...before an emergency or accident requires instantaneous judgment.

Vehicle integration provides added capability to your light and siren package such as: program and control all the lighting, traffic arrows and siren functions in your vehicle, flash pattern synchronization, canine alarm and temperature monitor control, radar and camera activation, door or trunk opening, window down, gun lock, ignition disable and much more. The abilities of Cantrol WC are limited only by your imagination...

Configuration is easy with a Windows® based computer program. USB port allows for easy program transfer from your computer to the amplifier/control module.

CANTROL™ WC

Amplifier/Control Module



CANWC1



Choice of Control Heads



CANCTL1

Standard microphone
CANCTL1/ 6



CANCTL6



CANCTL5

FEATURES

- Full function amplifier/control module.
- Program and control all the lighting, traffic arrows and siren functions in your vehicle.
- All outputs have both short circuit/over-current protection.
- WeCan® lightbar plugs directly into the amplifier/control module and is programmed by the CanTrol software.
- Inputs for three different style control heads (ordered separately).
- Three analog inputs for temperature sensor, ambient lighting, etc.
- Integrated battery voltage monitor.
- Supports one or two 100 watt speakers.
- Programmable for Hands-Free operation.
- 161 synchronizable, variable-phase, programmable flash patterns.
- Optional expansion module, up to two, allows for 16 additional 2-1/2 amp outputs per module, plugs directly into the WeCan port, for a total of 75 outputs.
- Over 45 programmable siren tones.
- Includes PA and radio repeat functions.
- Built-in system shut-down allows system to operate for up to four hours after vehicle is turned off.
- Redesigned housing with integrated diagnostic LEDs for quick troubleshooting.
- Optimized software.
- Easy to configure using Windows application program.
- Pre-configured programs may be modified and stored for ease of service. Easily extract your custom program and transfer to other vehicles.
- USB port in the amplifier/control module allows easy access for programming.
- Power and input/output cabling with connectors, standard.
- Five-year HDP® Heavy-Duty Professional warranty.
- Each output has diagnostic indicator.
- Eight inputs for customer supplied external switches; four for use on positive or ground switching, and four for use on positive switching only.
- Thirty-two 2-1/2 amp outputs.
- Three low current 1/4 amp outputs.
- Eight programmable 10 amp outputs.
- Three Diagnostix™ system indicators.
- Traffic Advisor™ module for traffic arrows that utilize a 9C cable eliminating the use of a traffic arrow controller.
- WeCan lightbar Traffic Advisor can be synchronized with remote Traffic Advisors that utilize a 9C cable.
- Meets or exceeds all applicable SAE, California Title XIII and NFPA requirements with various Whelen speakers, control heads and light-heads.

WHELEN®

CANTROL™ Light and Siren System

**SOLD THROUGH AUTHORIZED
CONTROL DISTRIBUTORS ONLY!**

CANWC1 Amplifier/Control Module

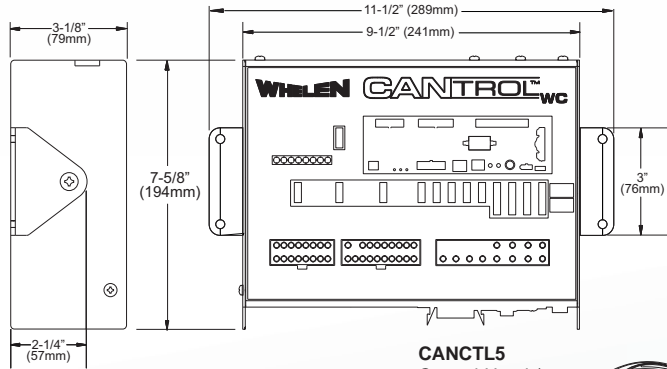

CANCTL5 Control Head / Microphone

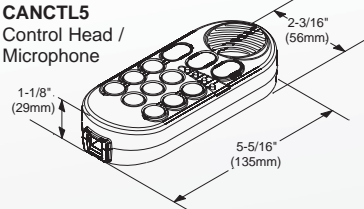

CANCTL1 Control Head

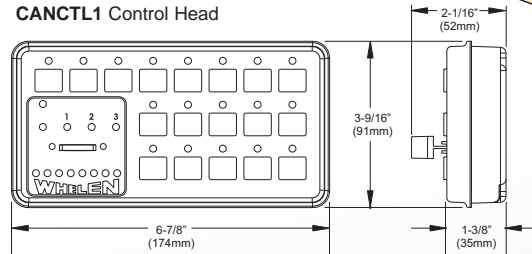

CANCTL6 Control Head

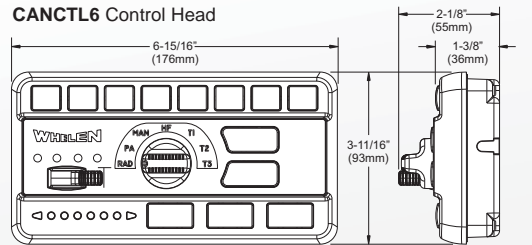

MODEL

CANWC1 Includes standard amplifier/control module with sixteen sixteen, 2-1/2 amp outputs, three low current 1/4 amp outputs, and control head of choice. Traffic Advisor™ module, eight total programmable outputs (four 10 amp pos/neg and four 10 amp pos only), an additional thirty-two 2-1/2 amp outputs and three Diagnostix™ indicators.

CONTROL HEADS

CANCTL1 Includes 3-position slide switch, eighteen push-buttons, standard microphone with extension cable.

CANCTL5 Includes a combination hand held microphone and controller, 3-position progressive light/siren control, nine push-buttons.

CANCTL6 **NEW!** Includes a 3 section control head with 8-push-buttons, 4-position slide switch and a 7-position rotary knob. Manual, Airhorn plus 3 Traffic Advisor switches and standard microphone with extension cable.

OPTIONS

CANEM16 16 output expansion module.

CANLITEB Light sensor in Black housing.

CANLITEC Light sensor in Chrome housing.

CANTEMPB Temperature sensor in Black housing.

CANTEMPC Temperature sensor in Chrome housing.

CANR1# 1 DUO™ Linear-LED® Raider, 5.5" long, Amber, Blue, Red and/or White, for use the CanTrol Only.

Replace # in model number with LED color desired.
D=Red/White, E=Blue/White, F=Amber/White, J=Red/Blue, K=Red/Amber M=Blue/Amber.

If you can think of it, CanTrol can do it!

- Activate your take-downs, alleys and/or spotlights by turning on the vehicle's high beams.
- Flash your Unity® Super-LED spotlights from any switch.
- Automatically switch rear facing lightheads to low power when vehicle is placed in park during nighttime operation, restore high power when vehicle is shifted back into drive.
- Synchronize entire vehicle lighting, such as all driver side lights alternate with all passenger side lights.
- At night when driver door opens, CanTrol automatically turns off alleys and end lights then turns on compartment lights.
- Flash only driver side or only passenger side of the vehicle, ideal for DUI situations.
- Use brake sense to turn on rear of lightbar and rear vertex or other lights to a steady mode, as additional brake lights.
- Activate Howler™ with brake pedal when siren is on, for a single cycle while you proceed safely through an intersection.
- Change any warning light flash patterns to mimic different siren tones.



CANWC1



CANEM16



CANCTL1



CANCTL6



CANCTL5

Standard
microphone
CANCTL1/ 6

Siren Tones

- 392 AVF
- 800 HZ
- Airhorn
- Airhorn Hi/Low
- Alarm
- Alternate Wail
- Alternate Yelp
- Composite Hi/Low 1800 1400 List
- Composite Hi/Low 2800 2000 List
- Composite Piercer
- Composite Wail
- Composite Tritone
- DIN Hi/Low
- FRA AF • Hi/Low
- Hi/Low 466p
- Hi/Low 500-660
- Hi/Low 510-1150
- Hi/Low 610-760
- Hi/Low GEN
- Hi/Low POL
- Hi/Low SPO
- Hi/Low UMH
- K9 Alarm
- Manual Coast
- Manual Stop
- Martin Hi/Low
- Mechanical
- Mechanical Coast
- Mechanical Stop
- Mechanical Wail
- No Tone
- PA
- Piercer
- Pulsed Airhorn
- Pulsed Piercer
- Radio
- Tritone
- Wail
- Wail 378p3
- Wail 850-1700 4s 5.25s
- Wail Yelp
- Wail Yelp Piercer
- Warble
- Warning
- Warning Chirp
- Woop
- Yelp
- Yelp 225
- Yelp 249



WHELEN®

ENGINEERING COMPANY, INC.

51 Winthrop Road
Chester, Connecticut 06412-0684
(860) 526-9504 • Fax: (860) 526-4078
www.whelen.com

Whelen Engineering reserves the right to upgrade and improve products without notice.
© 2013 Whelen Engineering Company, Inc. Printed in U.S.A.
Code No. 12373H - 093013

American Employees, American Manufacturing, American Pride!